

POWERED FLEX WORKSHEET



Company _____ Date _____
Contact _____ Quote Due _____ Desired Delivery _____
Phone No. _____ Contact Email _____ State _____
Sales Contact _____ Quote #: _____
Quantity _____

PRODUCT SPECS:

Max:

Width (inches): _____ Length (inches): _____
Height (inches): _____ Weight (lbs): _____

Min:

Width (inches): _____ Length (inches): _____
Height (inches): _____ Weight (lbs): _____
Description: _____
Max. Qty.: _____ Total Live Load: _____
Capacity Limitations (must meet all three)
15 lbs/roller, 50 lbs/ft, 100 lbs/zone

Roller Specs:

- 1.4" roller diameter, 18 ga.
- 1.9" roller diameter, 16 ga.

Application Type:

- Transportation
- Accumulation
- Loading
- Unloading
- Both

Conveyor Construction:

- Between Frame (BF): 18" 24" 30" 36"
- Expanded Roller Centers: 3" 4" 5"
- Expanded Length: 25' 40' 50' 60' 80'
- *Note: custom lengths are available, consult factory
- Casters: 5" 6" 8"

Height:

- 30" TOR, +/- 4" adjustment
- 34" TOR, +/- 4" adjustment
- _____

Speed:

- Variable _____ to _____ FPM

Options:

- Flexible Side Guides
- Reversing Stop
- Interface Kit
- Stopping Photo-eye

Approval Drawing Required: Yes No

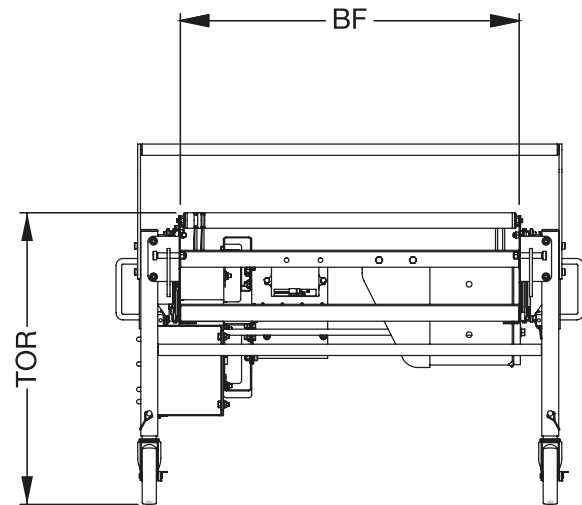

Impact Cart:

- Integrated
- Stand Alone
- 1.9" roller diameter, 16 ga.
- 2.5" roller diameter, 10 ga.
- Powered
- Gravity

Notes: _____

